

Smart Device Guide Powered by Hybrid Methanol–Solar Energy for Public Transportation

Fatemah Alissa, Teaf Almutlaq, Wala Aljobran, Aseel Bukhari, Ghadah Aljaffer, Reham Aljohani
Coach: Dr. Zuhair Al-Yousef

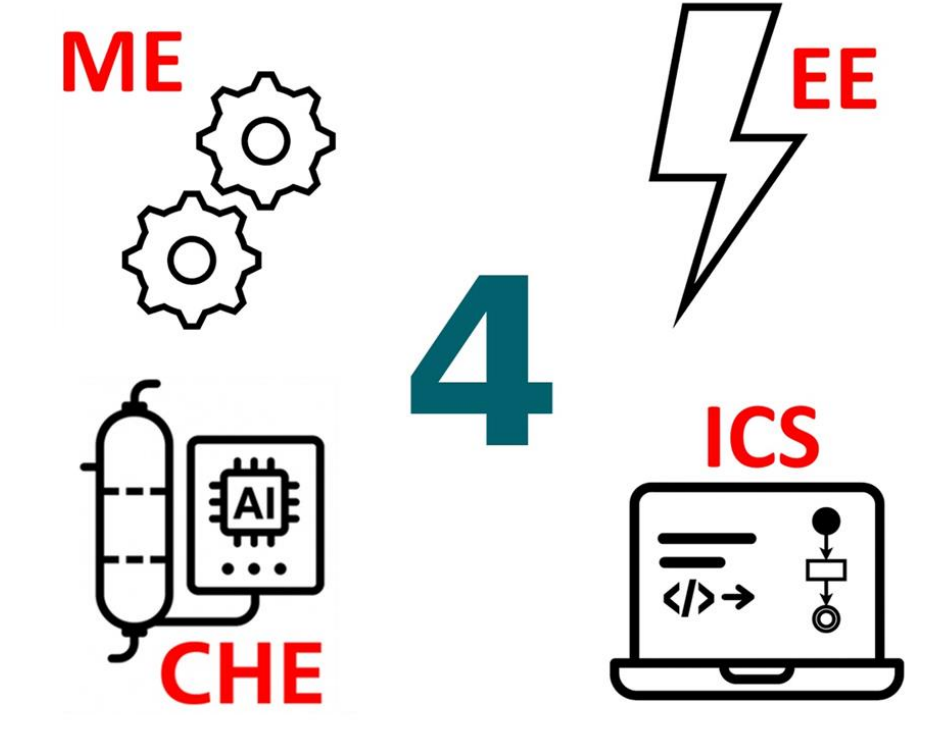

Introduction

- **Elevator Pitch:**
Our project is a smart guidance device powered by hybrid methanol–solar energy. It helps passengers in metro and bus stations by providing route guidance, schedule updates, and multilingual support through an interactive touchscreen.
- **Problem Statement**
Passengers in large public transportation stations often face confusion, delays, and language barriers, especially during busy hours. Traditional signs and help desks provide limited real-time and personalized assistance.

Objective

Public transportation stations often face problems such as crowded areas, passenger confusion, language barriers, and lack of real-time guidance. The objective of this project is to develop a smart guidance device that helps passengers navigate stations using multilingual support, touchscreen interaction, real-time route guidance, and sustainable hybrid energy sources.

Prototype Design

- Touchscreen Interface
- Hybrid Power System (Solar + Methanol Fuel Cell)
- Battery Backup System
- ESP32 Communication Controller
- Cooling Fans
- Aluminum Chassis Structure
- Route Guidance Software

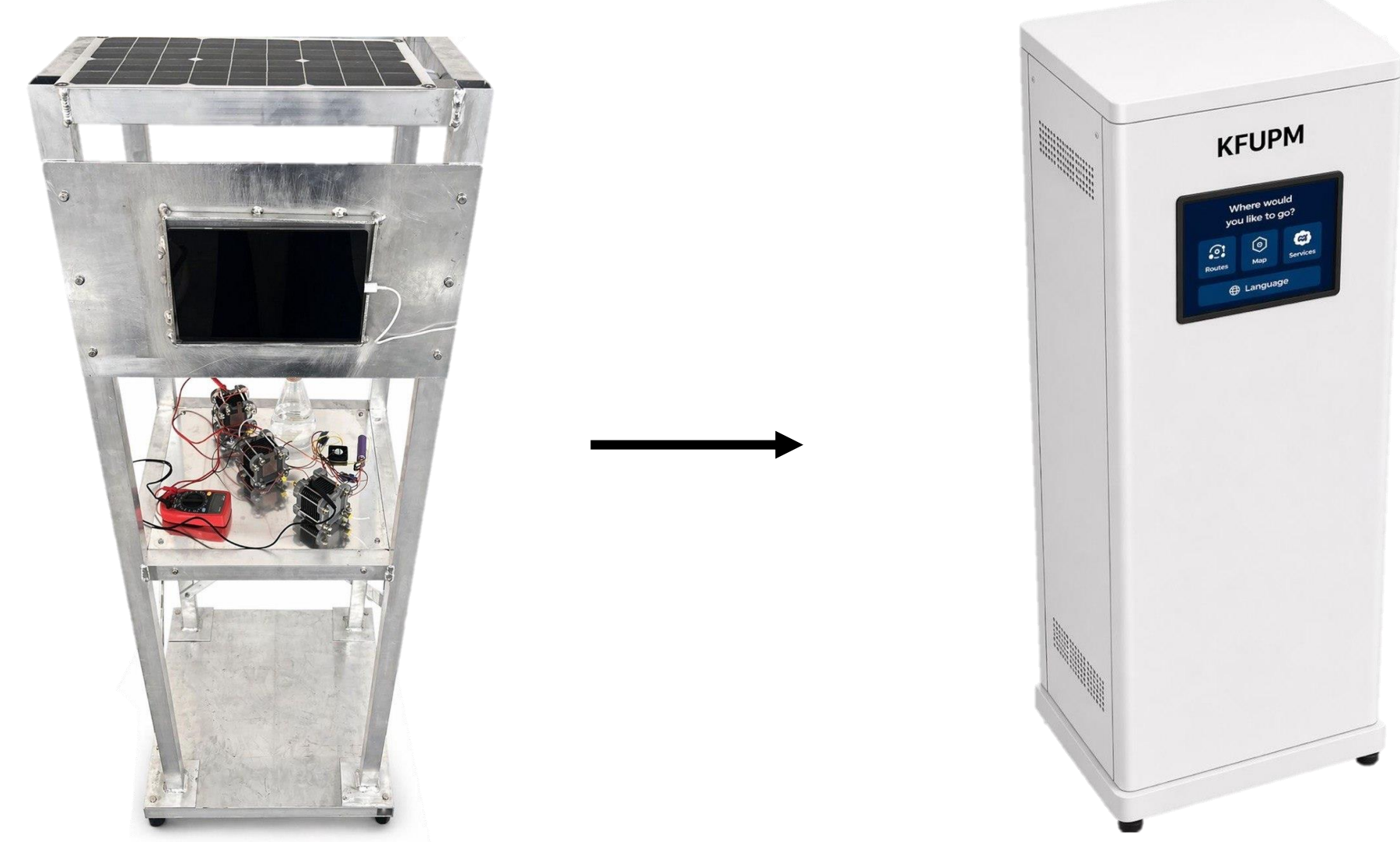

System Design

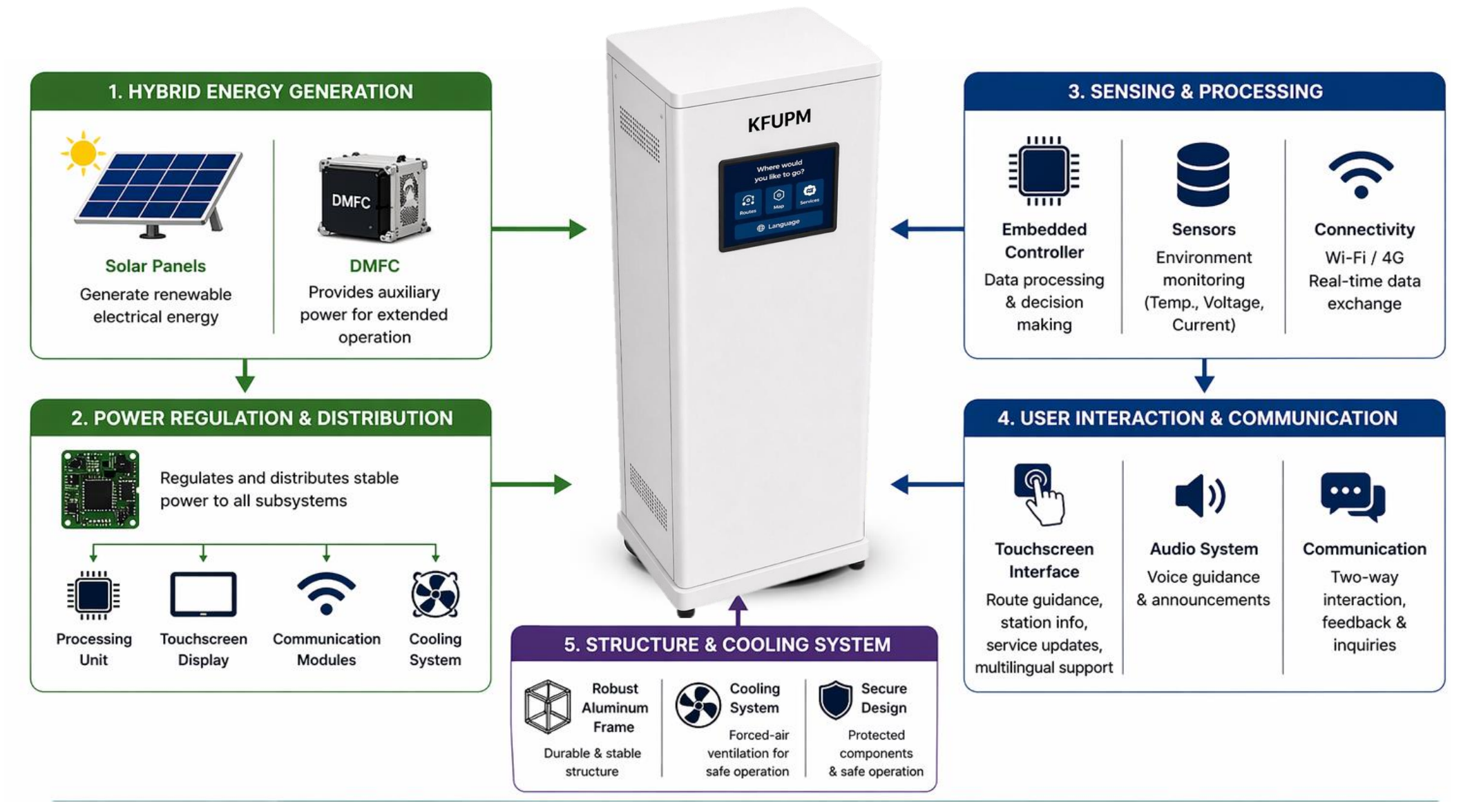

Constrains

- Budget ≤ 15,000 SAR
- Chassis mass ≤ 28 kg
- AES-128 security
- Screen size > 10 inches

Specifications

- Multilingual support for 4 languages (Arabic, English, Mandarin, Spanish)
- ML model accuracy ≥ 80% for path optimization.
- Operational duration ≥ 4 hours continuous runtime
- Power system generating at least 35 W from combination of renewable sources
- Response time < 2 seconds
- Refreshes data every 10 seconds minimum
- Wireless communication range ≥ 50 meters
- Touchscreen at least 10 inches
- Chassis deflection shall not exceed ≤ 4 mm under a lateral push force of 50 N applied at a height of 150 cm.
- Chassis shall not tip or lift any base corner when subjected to a lateral force of 50 N applied at a height of 150 cm
- Chassis can support internal payload at 25 kg

Validation & Testing

Testing and simulation verified prototype performance. DMFC voltage output was 6.22V, confirming stable power supply. FEA analysis showed chassis deflection within the allowable limit (≤ 4 mm), and chassis supports 25 kg payload with 1.7 FOS, validating system reliability and structural safety.

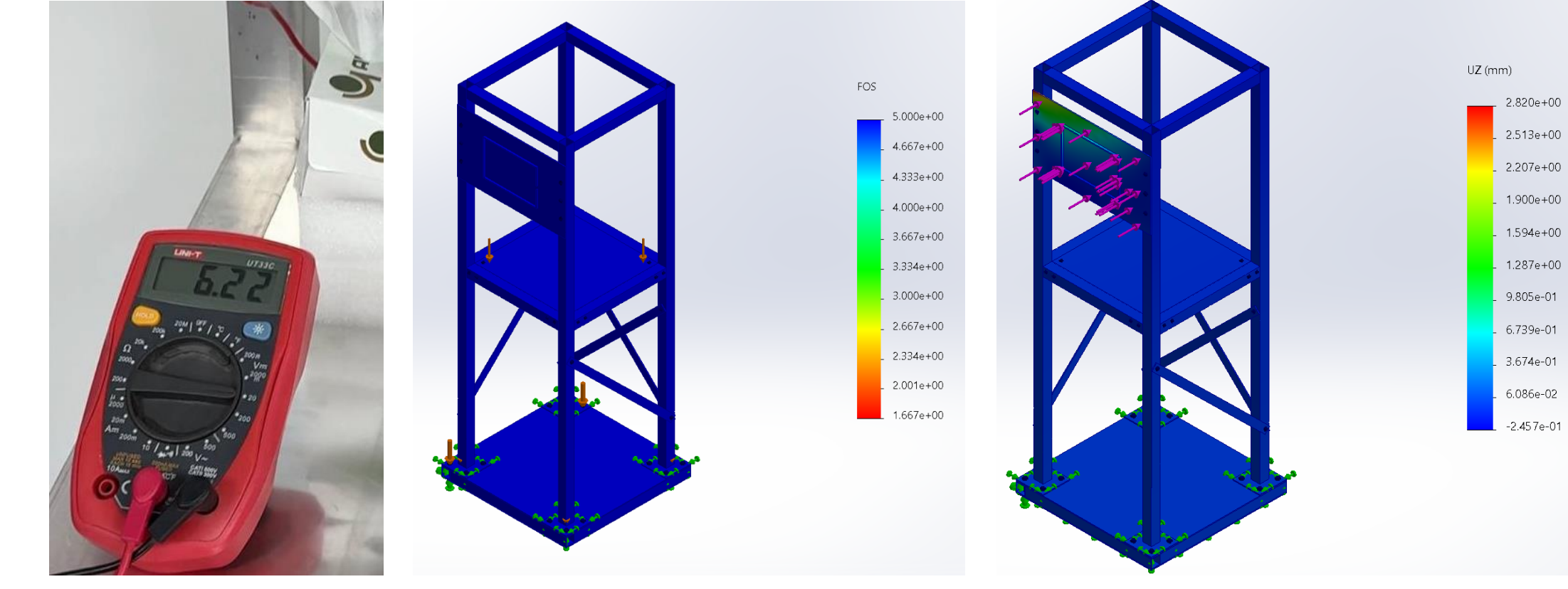

conclusion

The Smart Device Guide successfully demonstrated a reliable and sustainable solution for public transportation stations. The prototype met key specifications in guidance accuracy, response time, runtime, and system reliability. The integrated hybrid methanol–solar energy system and user-friendly interface confirmed the feasibility of improving passenger experience and station efficiency.