

CO₂ CAPTURE FROM THERMAL WATER DESALINATION PROCESS AND UTILIZING IT IN STRUCTURAL CONCRETE, CO₂ BATTERY, AND DISTRIBUTE THE SURPLUS TO THE MARKET

AUTHORS: Osama Alzahrani(CE) , Jihad Almuwallad(CE) , Osamah Al-Gazlan(CHE), Fahad Alghuwainem(CHE) , Abdulaziz Alareefi(ISE), Feras Alzahrani(ISE)



COACH: DR. HAMMAD RAZA KHALID

TEAM DESIGN: TERM 231

DEC 17, 2023

INTRODUCTION

Capturing CO₂ from Saudi Arabia's water desalination is crucial during climate change threats. Despite challenges faced by thermal desalination, its reliability in providing freshwater, potential for energy diversification, and existing infrastructure investments make it essential. Motivated by the goal of achieving net-zero carbon emissions by 2060, this initiative aligns with sustainable and resilient practices for the future.

CO₂ battery: To help the kingdom's ambitious renewable energy future, a reliable energy storage solution is designed using the captured CO₂.

Curing concrete with CO₂: Curing concrete with CO₂, also known as carbonation curing, is a technique that accelerates the curing process and enhances the strength and durability of concrete.

Project statement: CO₂ capture from thermal water desalination process and utilizing it in structural concrete, CO₂ battery, and distribute the surplus to the market.

IDENTIFICATION OF CONSTRAINTS:

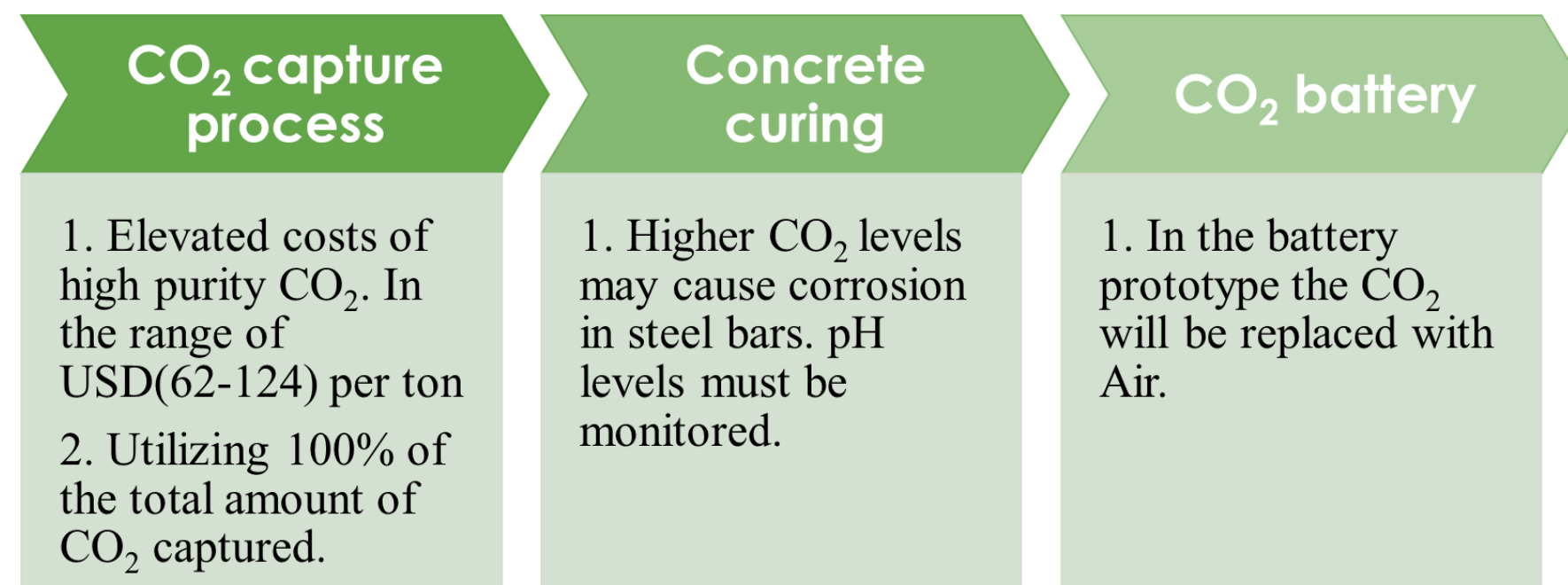

TARGET SPECIFICATION

CO ₂ Capture	CO ₂ Battery	CO ₂ Curing
<ul style="list-style-type: none"> CO₂ purity to 99.5% Pressure <7 bar Temperature < 260 °C Capturing efficiency > 90% 	<ul style="list-style-type: none"> Pressure of CO₂ battery process < 70 bar Round trip efficiency (RTE) of the CO₂ battery= 50% 	<ul style="list-style-type: none"> Optimize the pressure at 60 psi curing time for 10 hours 75 MPa strength in 28 days of curing

1- CO₂ UNIT DESIGN

An Amine scrubbing absorption unit operates with a lean amine of 35% Monoethanolamine and 65% water that captures sour gas from thermal desalination plant and produces **99.6% CO₂ purity**.

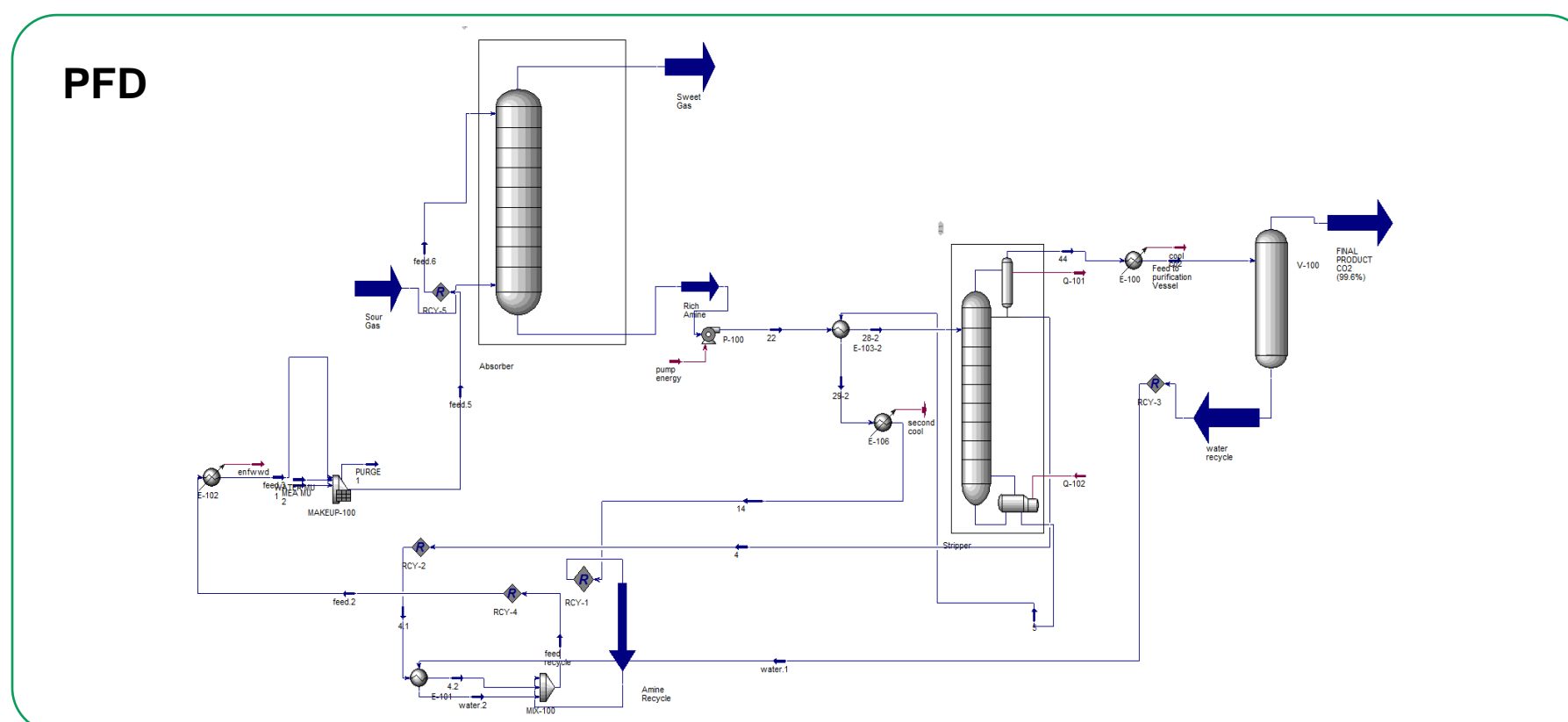

Specifications	Results
Capturing efficiency > 90%	95.20%
Pressure<7bar	3.1
Temperature < 260 °C	150
CO ₂ purity>99.5%	99.6

2- CO₂ BATTERY

An energy storage device stores and regulates excess renewable energy during peak production by compressing CO₂ to 70 bar using surplus energy, storing it in high-pressure tanks, and then expanding CO₂ to recover **65%** of the energy.

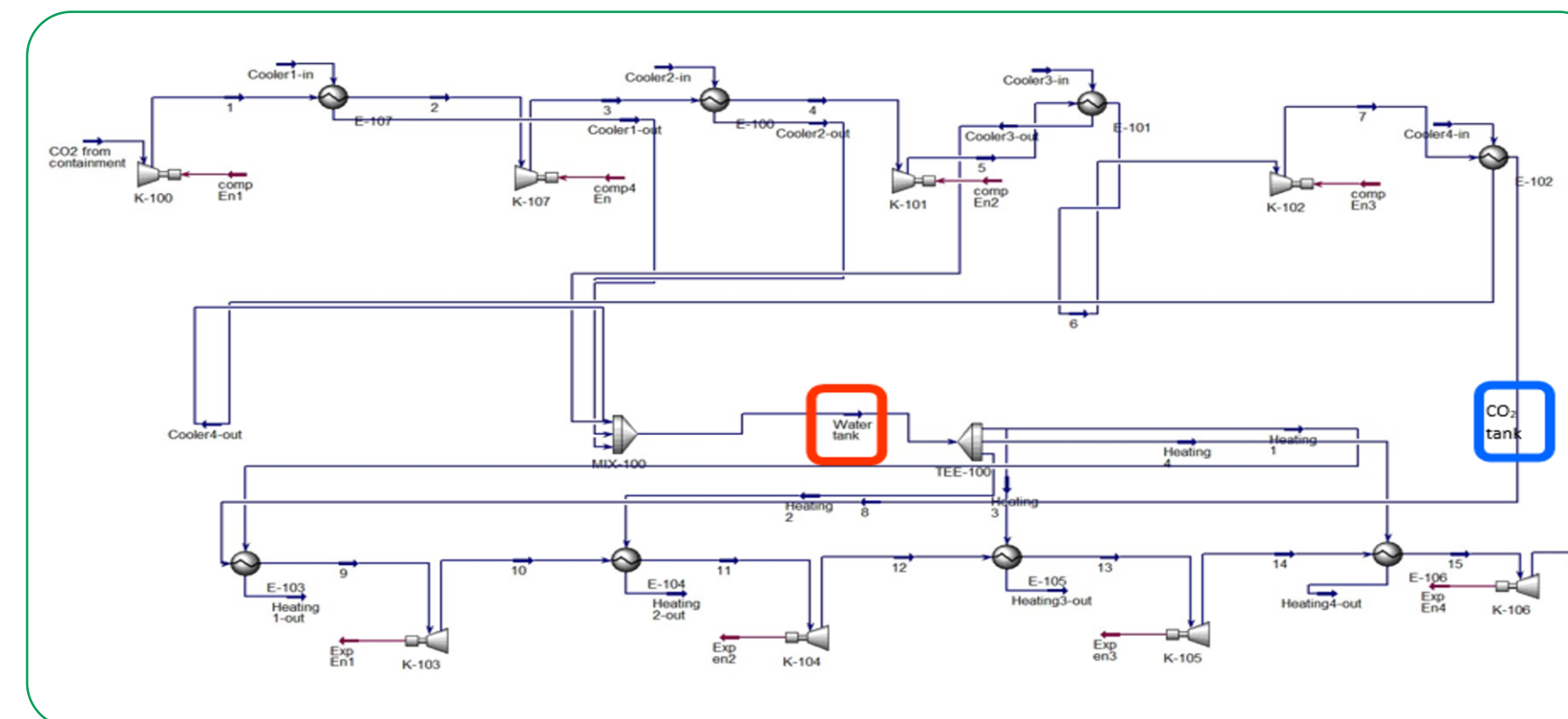

SPECIFICATION	MEETS OR DOES NOT MEET
Pressure ≤ 70 Bar	Meets (max P=70 Bar)
RTE=50%	Meets (RTE=65%)

The table above shows how the battery meets all set specifications.

Battery applications in the state of the kingdom's energy mix:

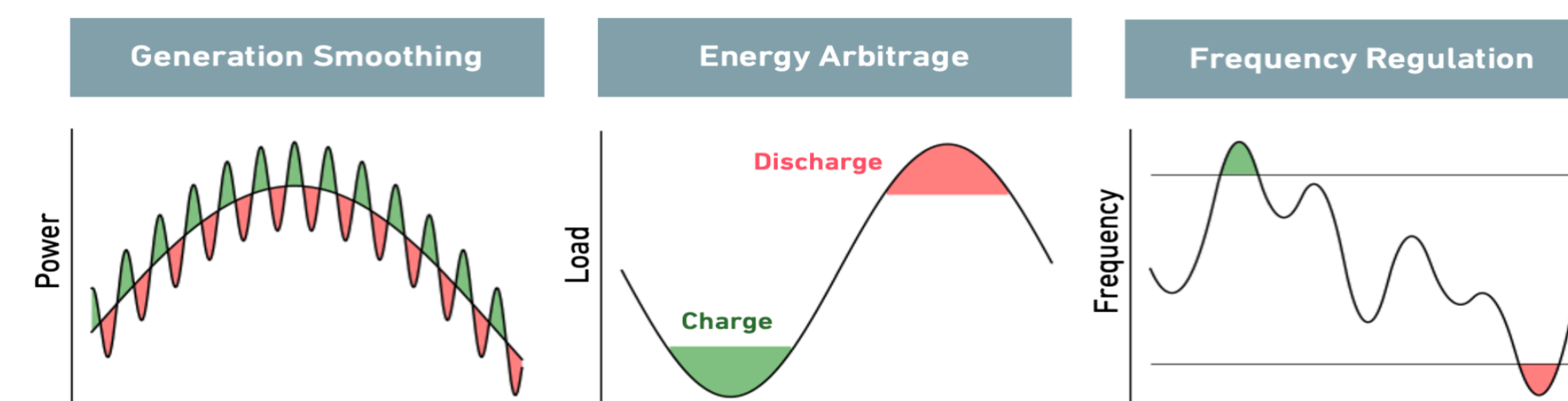

All these benefits come with a leveled cost of storage(LCOS) of **0.087 USD/kWh**, lower than the LCOS of Li-ion batteries which is at **0.17 USD/kWh**

3-CO₂ CURING:

The compressive strength of cement paste specimens was tested at long and short terms after exposing the samples to 3 different pressures and 3 different curing periods. Control samples was tested also to compare the results.

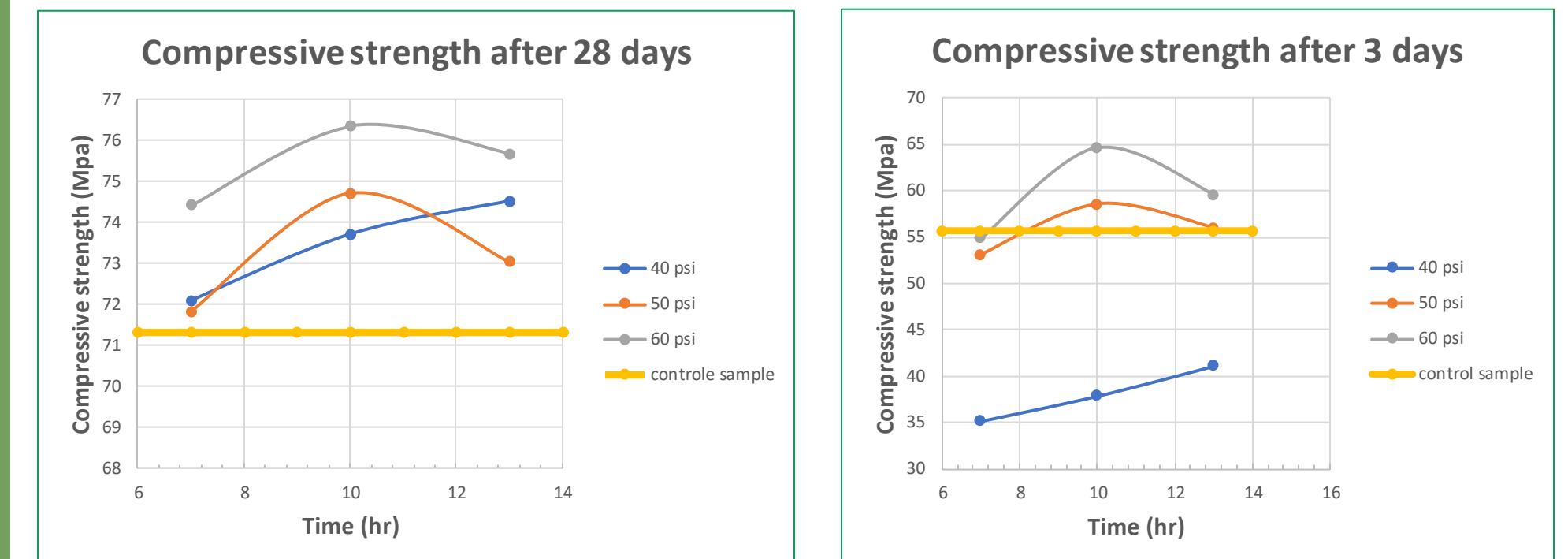

SPECIFICATION	MEETS OR DOES NOT MEET
Achieving 75 MPa strength in 28 days of curing	Meets
Optimize curing pressure at 60 Psi & Reduce the curing time to 10 hours	Meets (75 MPa strength achieved at this target)

CONCLUSION

In this project detailed CO₂ capture unit Which matches the water desalination plant in Al-Khobar. The product is planned to be used in carbon dioxide batteries and precast concrete. A **direct reduction of 16.4%** of the kingdom's total emission is expected. The yearly captured CO₂ is **1,332,396 tones**, this can produce:

