

Smart Portable Multi-Gas Detector

Introduction

Gas detecting, also known as gas detection or gas monitoring, is the process of identifying and measuring the presence and concentration of various gases in the air. The primary purpose of gas detecting is to prevent accidents, protect personnel, and minimize the risk of exposure to hazardous gases. Early detection enables prompt action to be taken, such as evacuating the area, implementing safety procedures, or shutting down equipment to prevent further gas release. Gas detectors can also be integrated into alarm systems to provide audible and visual alerts in case of gas leaks or high gas concentrations.

Project Objective

- Design a Multi-Gas Detector that can detect CO and H2S gasses.
- Program the Multi-Gas Detector to send the data to a server so that it could be accessed by the supervisor.
- Design a filter made of plastic to activated carbon as the material for removing the toxic gases.

Constraints

System footprint $\leq 14 \times 7.3 \times 3.2$ cm

Cost between 500-950 SAR

Weight < 350 g

detect two gases (H2S and CO)

List of Specifications

• Detect CO < 150 ppm.

It was reported by OSHA that the dangerous level of CO is 150ppm. Detecting CO below its dangerous level is crucial because it is highly deadly. Since it has no taste or smell and is practically impossible for people to detect on their own, carbon monoxide is known as the "silent killer". CO should be detected below its dangerous level to save the workers from great danger, because it cannot be detected by the sense of smell and once, they inhale more concentration above the dangerous level they will be in great danger.

• Detect H2S < 100 ppm.

It was reported by OSHA that the dangerous level of H2S is 100ppm. Detecting H2S below its dangerous level is crucial because it is highly toxic to people. Several different bodily systems can become poisoned by H2S, but the nervous system is the most vulnerable. So, H2S should be detected below its dangers level to save the workers. Although it has an odor at low concentration, the sense of smell is not enough to make sure it is H2S before it reaches to its dangerous level where it affects the olfactory system.

• Battery life > 8 hrs

A smart Portable multi gas detectors should have a long battery life to ensure reliable use in the field.

Testing / Validation

The final specification of the prototype:

- 1- Detect CO < 100 ppm.
- 2- Detect H2S < 50 ppm.
- 3- Battery life > 12 hrs

Looking at the final specifications, we can conclude that the prototype satisfies more than the preliminary specifications.

For the battery life, the total consumption of the device is 435mAh, and the battery used has a capacity of 5500mAh. Therefore, the battery life of the device is more than 12 hours, which is more than the required battery life.

System Overview

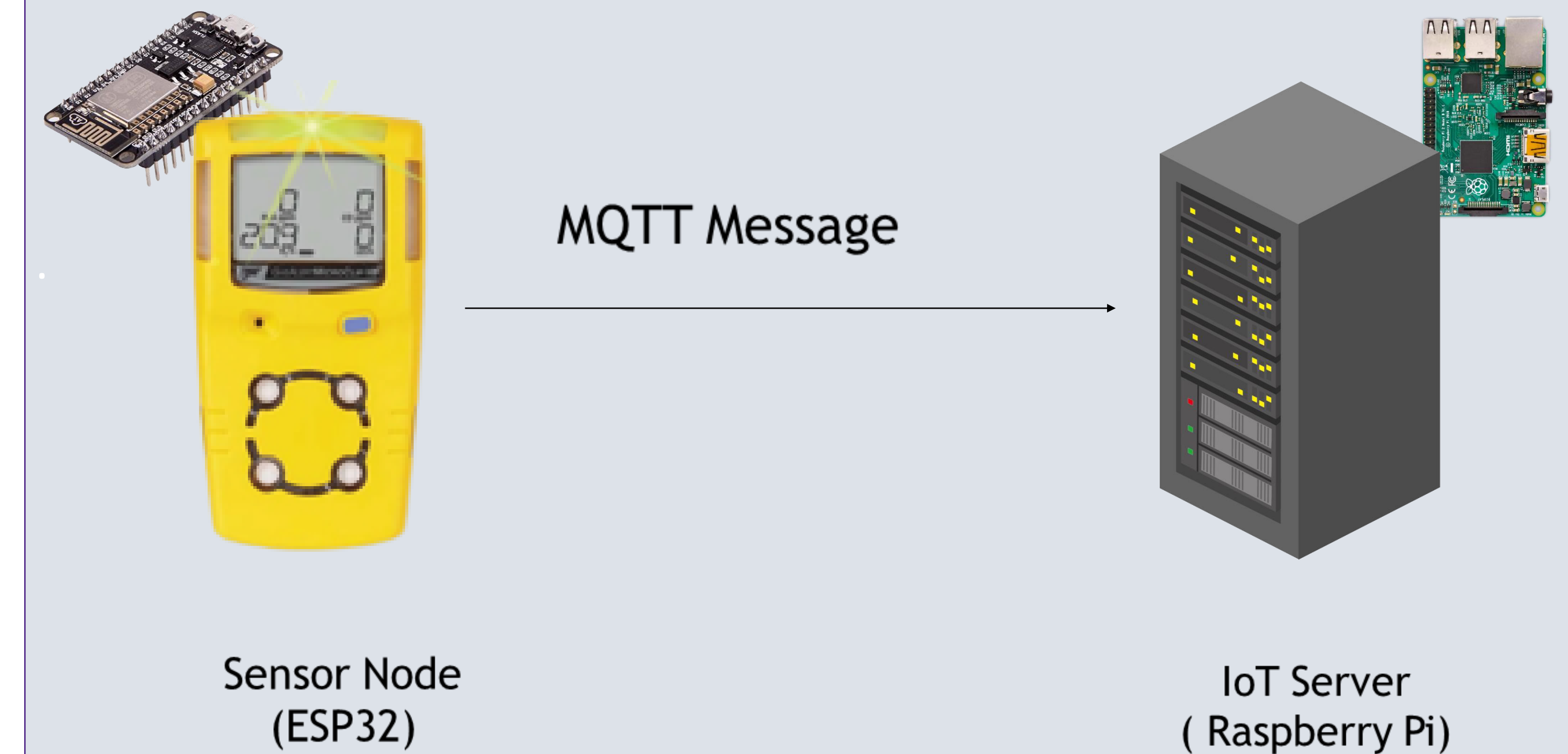

3D

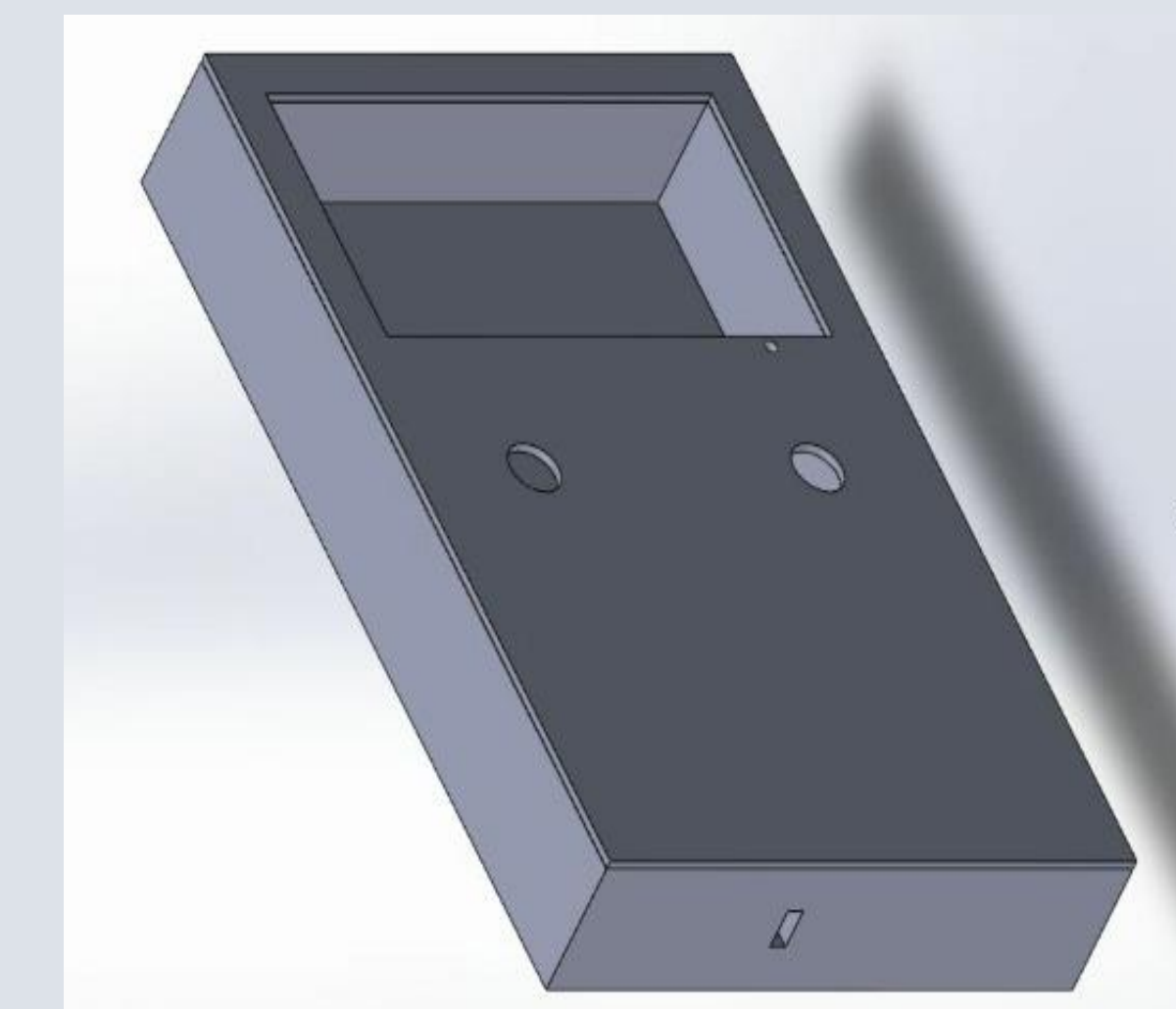

Detector

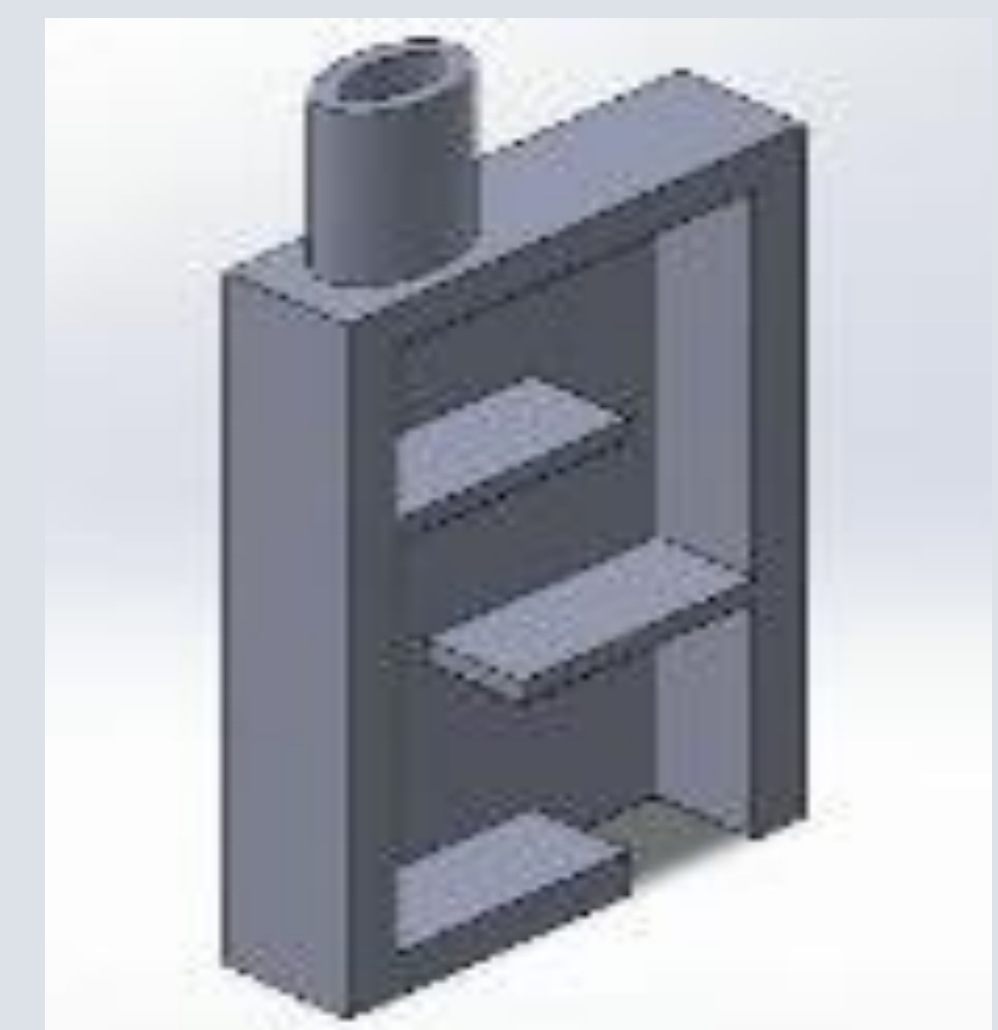

Filter

Conclusion

In summary, our senior project introduces a cutting-edge smart gas detector, uniquely identifying CO and H2S gases. Its distinct feature lies in seamless signal transmission to a control unit, setting it apart from market alternatives. This innovation enhances safety standards with precise, real-time awareness, showcasing the potential for significant advancements in gas detection technology.

Students Name

- Moath Almejnah
- Abdulaziz Alghamdi
- Badir Albassam
- Mohammed Aljoridan
- Abed Aljedani
- Mohammed Mubarak

Coach Name

Dr. Ibraheem Al-Naib