

Carbon Dioxide Capturing Using Amine Adsorption Technology



Team 59: Mohammed Alhammad (EE) - Murtadha Alghwainem (EE) - Sulaiman Alzamil (ISE) - Abdulrahman Gow (ISE) - Abdullah Taheini (CHE)

Introduction

Problem Statement:

These days industries are producing 37 billion metric tons yearly of CO₂ to operate their plants which has a bad impact on the environment.

Constraints:

- Most of the materials are not available in KSA The time.
- Lack of materials in designing the catalyst.

Target Specifications:

- Operation power of 180 watts.
- A fully automated device.
- Capturing 7.3 wt% of the CO₂.

Prototype Design

The prototype is compounded of two stages, adsorption and storing stage. And the given components are essential for the prototype:

1. CO₂ sensor
2. Solenoid valve
3. Vacuum pump
4. Pressure regulator
5. Water tank
6. PH sensor

Prototype design:

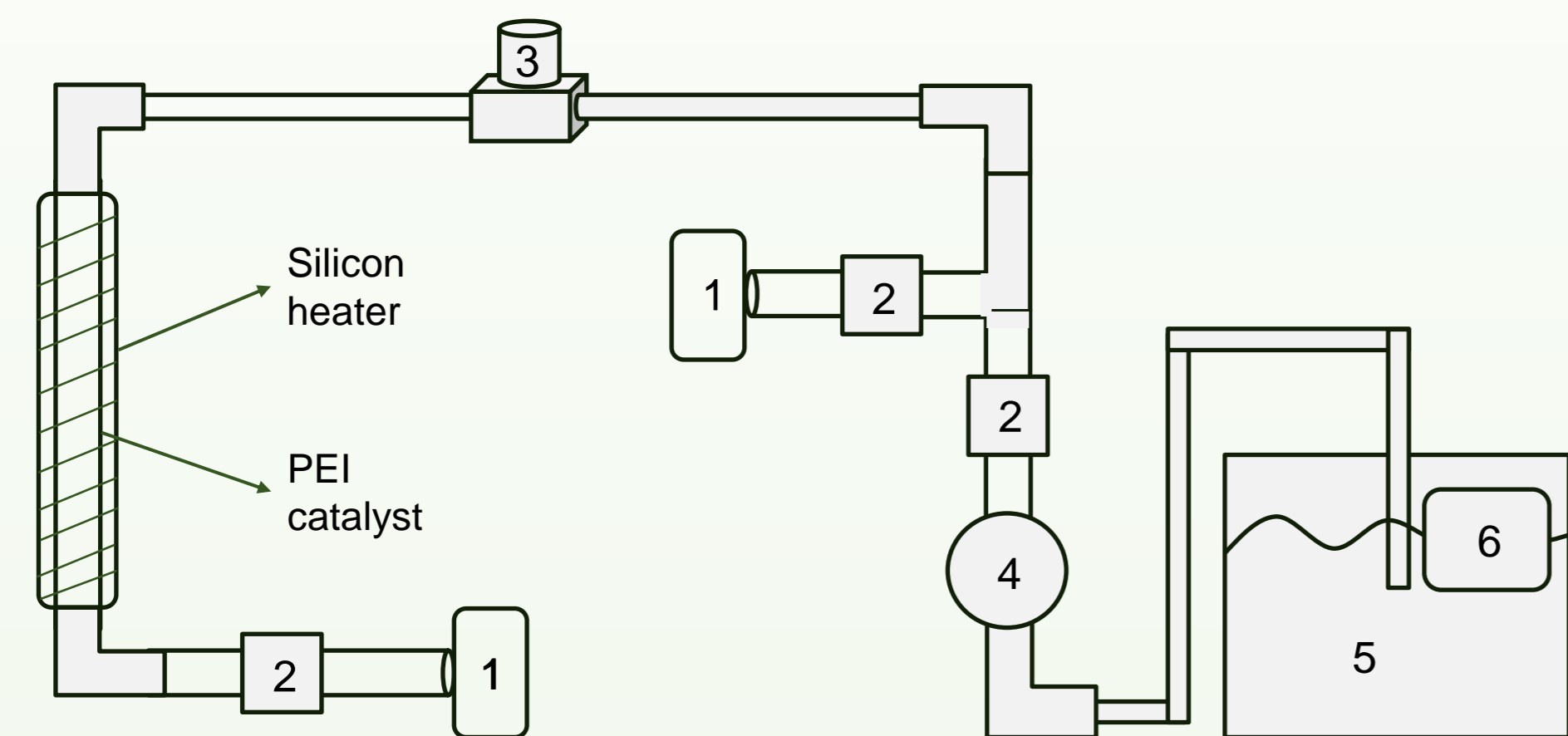

Figure 1. Prototype Design

How It Works

Adsorption stage:

At this stage, the inlet valve and the outlet valve will open then the vacuum will start running. Afterwards, the air will go to the catalyst, where the CO₂ will be captured, through the inlet CO₂ sensor to measure CO₂ concentration before capturing. Then the air will exist the device through the outlet CO₂ sensor to measure CO₂ concentration after capturing.

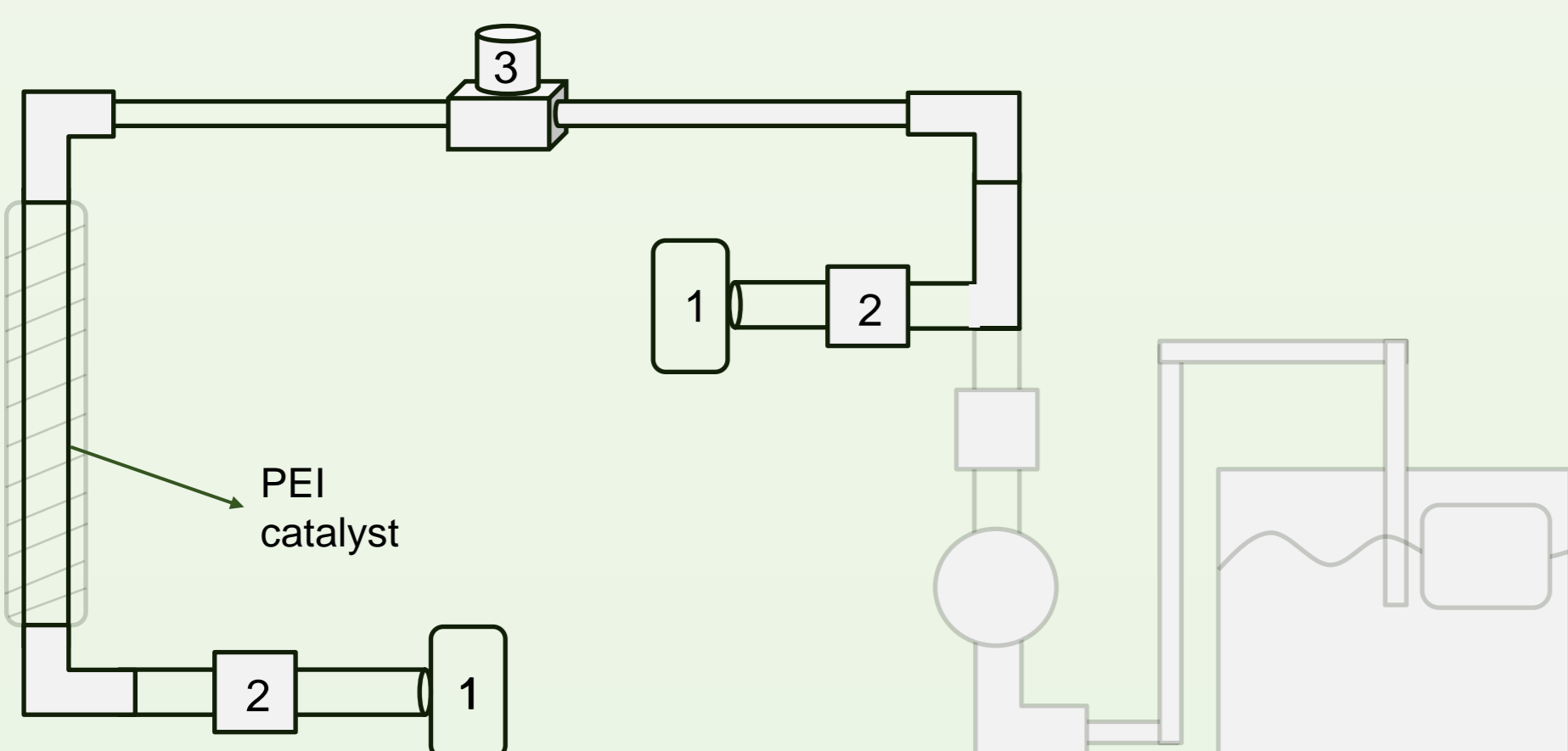

Figure 2. Adsorption Stage

Storing stage:

At this stage, the outlet valve will close, and the silicon heater will heat up the catalyst. Then, the captured CO₂ will be released from the catalyst. After that, the released CO₂ will pass through the water tank valve and the pressure regulator to the water tank in to get carbonated water.

Function of product

Producing low carbon emission products serves several important functions, contributing to environmental sustainability and addressing climate change. Here are some key functions and benefits associated with the production of low carbon emission products:

- Mitigating Climate Change
- Environmental Preservation
- Regulatory Compliance
- Consumer Demand

Quality Control Chart

A fundamental tool in quality management and process improvement. It contributes to the effective control of processes, reduction of defects, cost savings, and the enhancement of product and service quality.



Figure 3. Control Chart at 100 °C for mmol of co₂ /g of adsorbent

Electrical Circuit

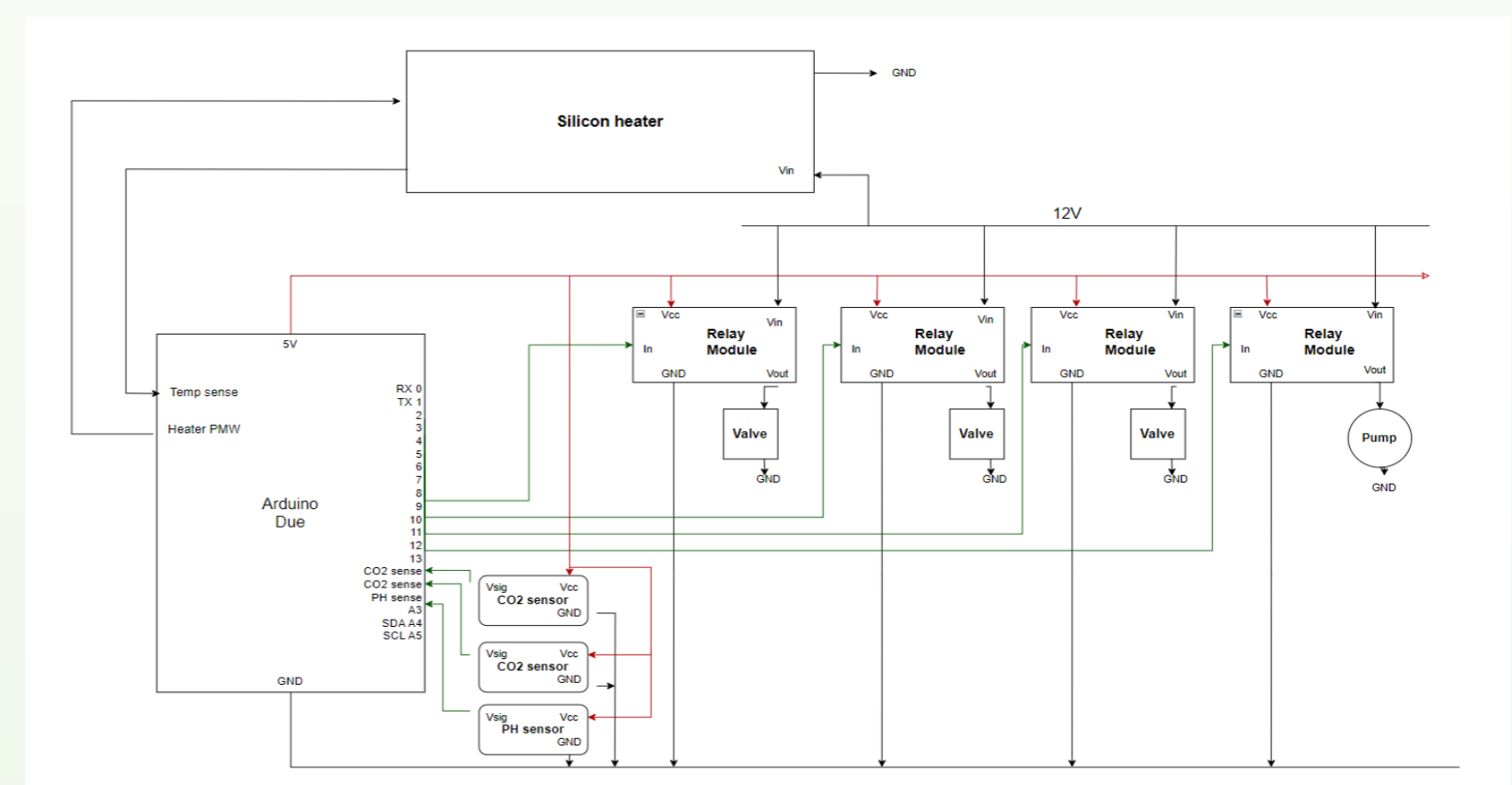

Project Impact

Carbon dioxide capturing using amine adsorption technology has significant implications for the environment, society, and the economy. Here are the key impacts in each area:

Environmental Impact:

Reduced emissions, air quality improvement, and environmental preservation.

Societal Impact:

Health Benefits, Public Awareness and Education, and Community Engagement

Economic Impact:

Market Opportunities, Regulatory Compliance, Resource Efficiency:

Conclusion

To conclude, the significance of the work lies in the fact that branched PEI impregnated on zeolite could trigger higher adsorption capacity at optimum reaction parameters as reiterated further from the kinetic modelling study. The present study is believed to be a cost-effective approach that can be extended to simulated flue gas conditions for a broad scope of the CO₂ capture study application. Further studies on the impregnation of different molecular weights of PEI amine on zeolite, along with the effect of the binder on palletization in a simulated flue gas conditions would help in demonstrating these adsorbents role better in mitigating climate change by capturing CO₂ in a simple and economical approach.