



BACKGROUND

Project Statement

- Our project aims to design a functional prototype of a 3D filament extruder that can produce high-quality filament from raw PLA pellets
- The project is motivated by the need for a cost-effective and accessible source of filament

Constraints

- Short project timeline
- Limited access to materials and parts in Saudi Arabia

Target Specifications

- Producing a filament diameter of 1.75mm
- A consistent flow rate of 83 g/h
- A temperature range of 170-250°C



THE NEED

- Cost-Effective Filament Production
- Custom Filament Properties
- Sustainable Production

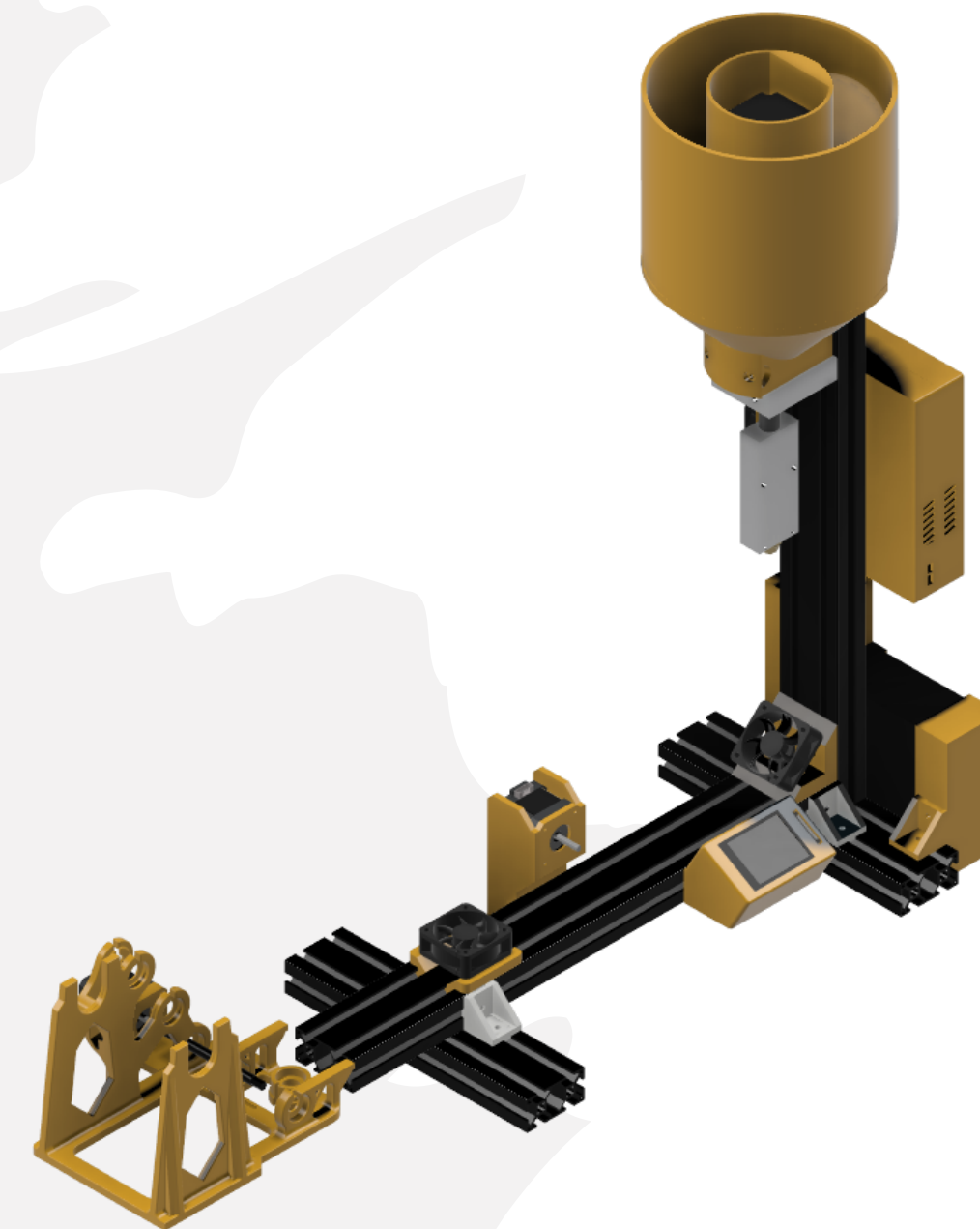

DESIGN

Extruder

- the core of our system
- responsible for the precise deposition of material
- fundamental to the overall performance and quality of the product

Cooling System

- maintain the optimal thermal environment during the filament extrusion process.
- 2 fans are integrated in our final design based on PLA heat capacity

Spooling & Diameter Sensor

- introduces a sophisticated layer of automation and quality control.
- incorporation of diameter sensor enhances real-time monitoring of filament diameter



TEST & VALIDATION

- By running the extruder at the PLA melting Temperature, we were able to extrude 83 kg/hr
- The 2 fans were sufficient to cool down the filament to a spool-able condition
- The spooling mechanism and sensor were able to keep the filament within the acceptable radius while successfully spooling the filament



CONCLUSIONS

- Our project seeks to open up the 3D printing industry enabling everyone to realize their creative potential.
- By making PLA filament production more affordable and accessible, we may stimulate an innovations that cuts across industries, encourages creativity, and eventually works toward making the world more sustainable and interconnected.