



# CubeSat Power System Capstone 2.0, Cluster 2



Students' names (Dept.):

Osama AlGhanim (EE)

Ahmed AlMutlaq (EE)

Abdulmajeed Alsahud (ICS)

Talal AlJabr (EE)

## INTRODUCTION

### • Problem Statement:

The main objective of this project is to design efficient power and control systems to increase the lifetime of CubeSats by minimizing power consumption and optimizing power supply and storage.

### • Constraints:

1. Time
2. Budget

### • Target specifications:

1. Payload: A power system that can deliver approximately 2W & 5V to payload.
2. Power generation: Each solar panel does not exceed 8.5×8.5 cm, and the whole solar panel system should generate more than 2W.
3. Power storage: two batteries are used, each battery is 1300mAh & 3.7V.
4. The weight of the power subsystem must not exceed 0.8 kg.

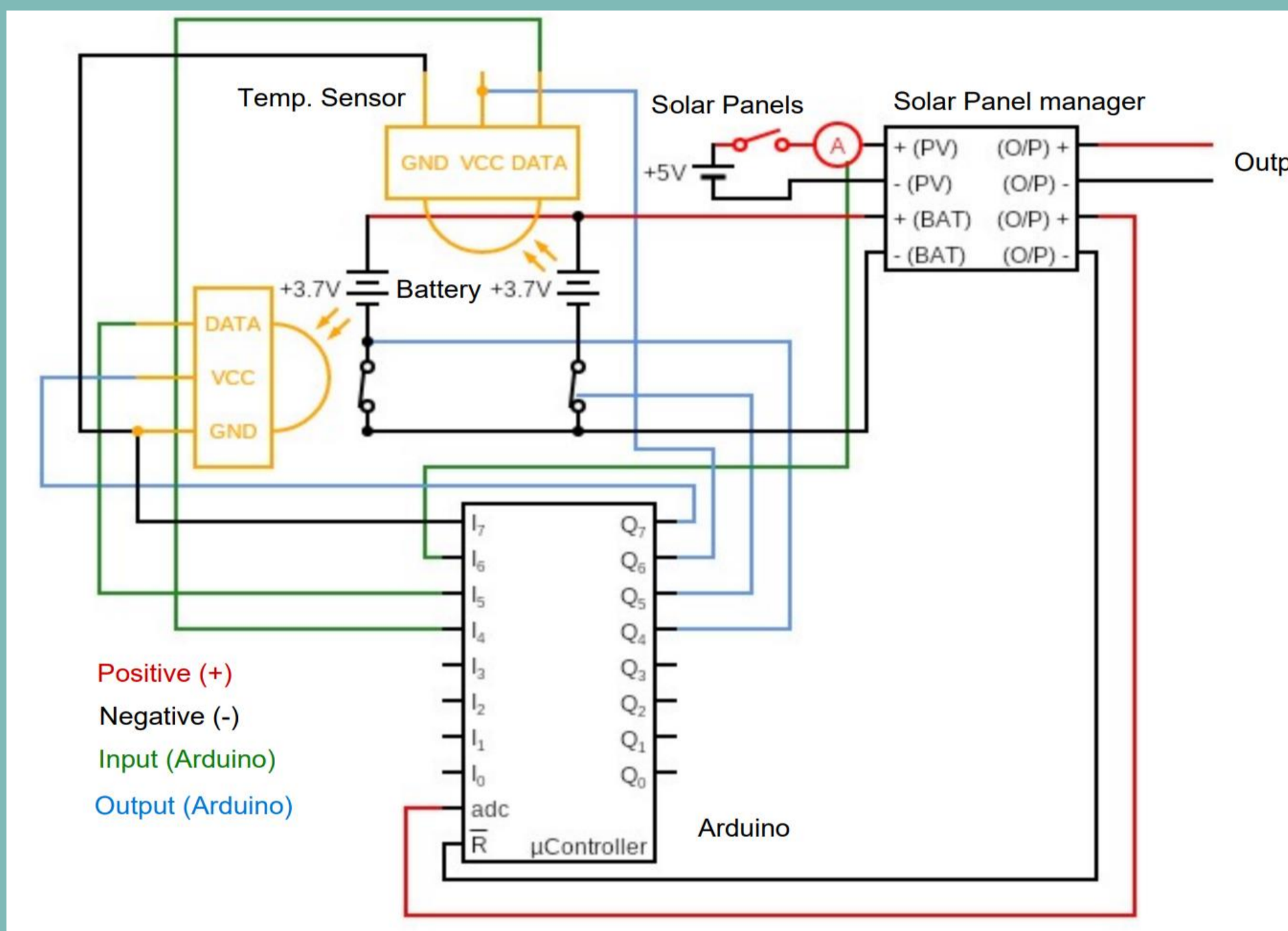
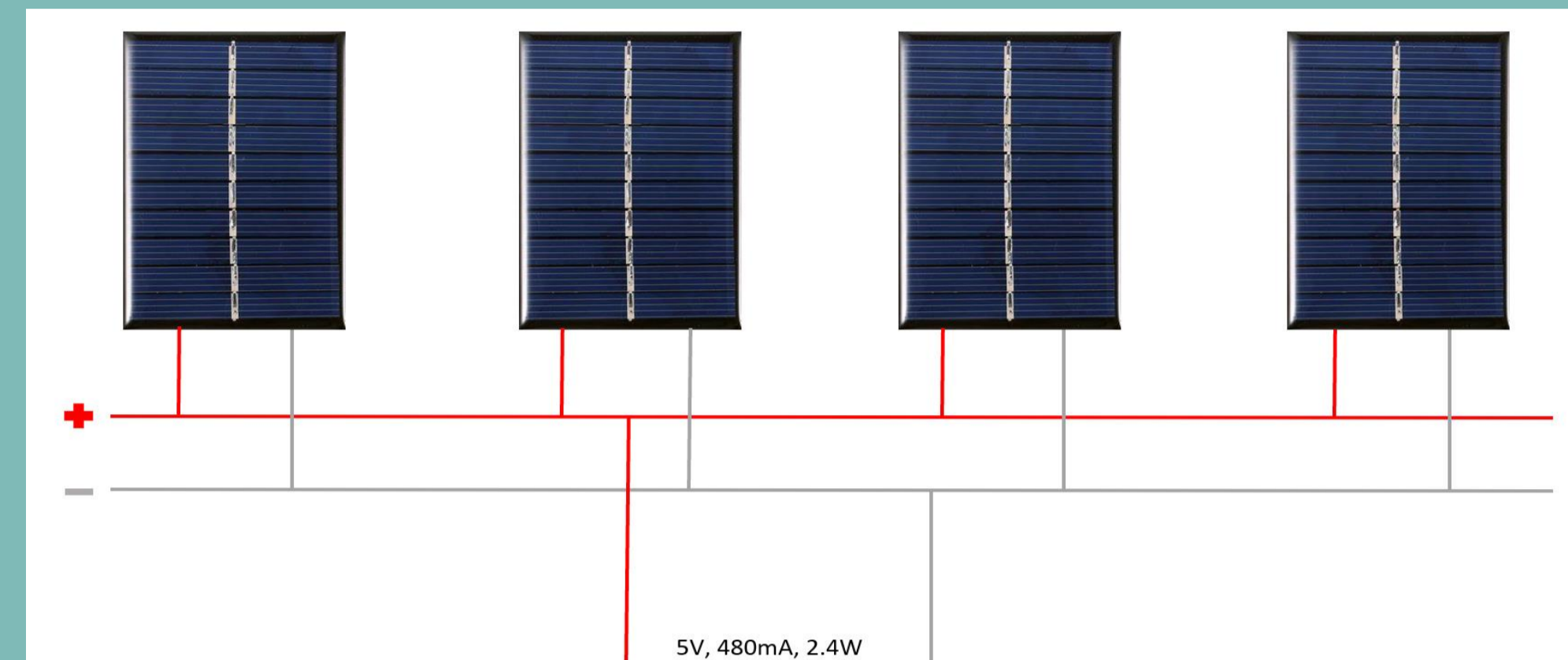

- The power from the solar panels is 39% higher than the specified power.
- The weight of the power system is 70% lighter than the specified limit.
- To conform with specification (4), each component was scaled to determine its' weight as shown in the following table.



Battery current



Battery voltage



Output voltage



Solar Panels' current (max)



Solar Panels' voltage (max)

## PROTOTYPE DESIGN

The main goal of this project is to provide the amount of power required to operate the CubeSat for the whole time of its mission. The power subsystem of the Consists of two parts as shown below, the power source and power distribution.

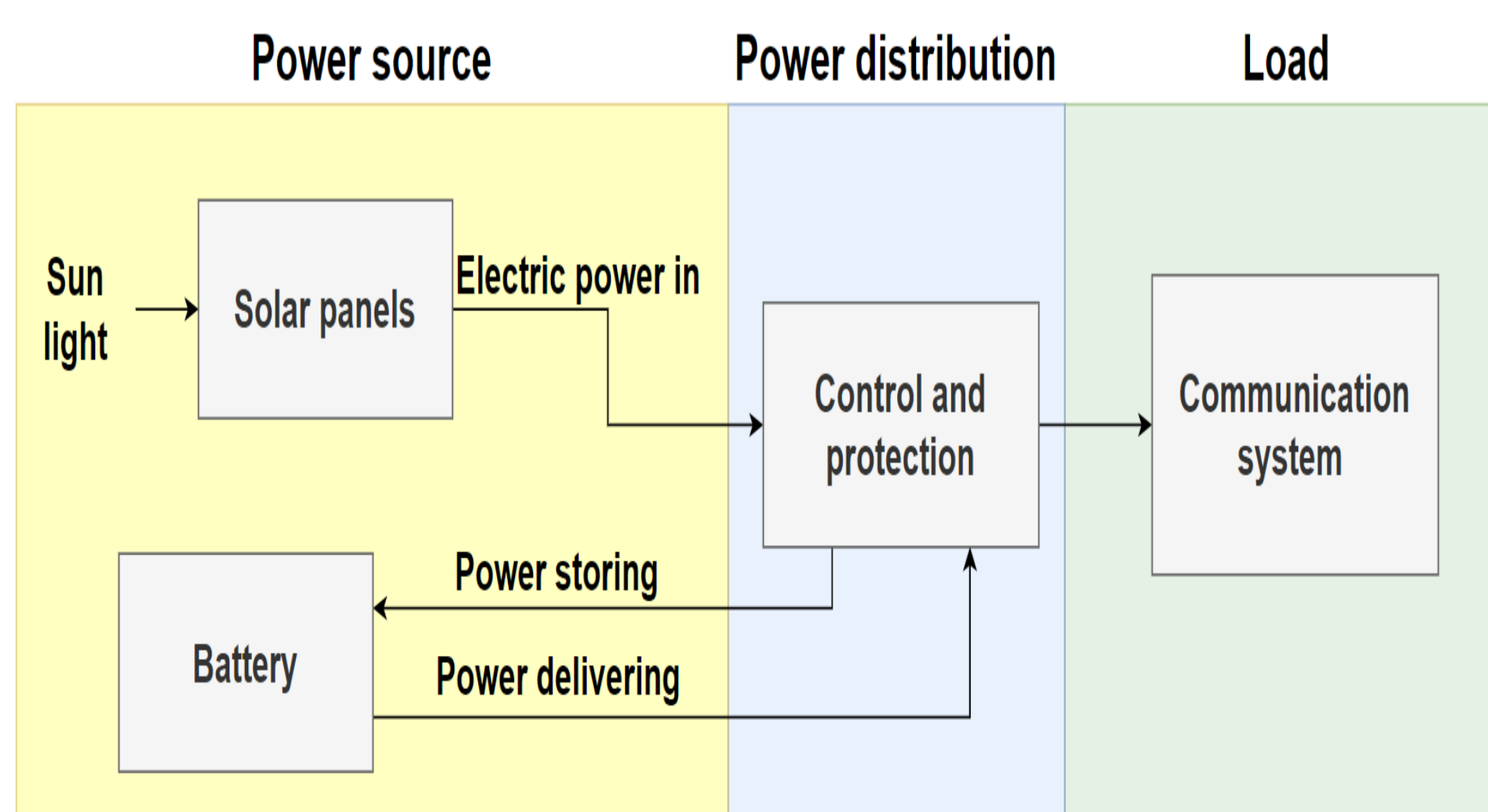

## TESTING / VALIDATION

- To validate specifications (1), (2), & (3), The power of the solar panels and batteries were calculated using current & voltage measurements as shown in the following pictures. The output power for the solar panels is 2.781W (2), fully charged batteries provide 2.3W, thus the tests also verify specification (1).
- To meet specification (2) regarding the solar panels' dimensions; the dimensions of one solar panel that is used are 8cm×5.5cm×0.3cm with 0.2mm error.
- To meet specification (3) regarding the battery capacity; each used battery is 1300mA.

| Component               | Weight                     |
|-------------------------|----------------------------|
| Solar Panels            | 0.073 kg                   |
| Batteries               | 0.05 kg                    |
| Solar panels            | 0.013 kg                   |
| Arduino                 | 0.028                      |
| Switches                | 0.006 kg                   |
| Current sensor          | 0.006kg                    |
| Temperature sensors     | 0.0002 kg                  |
| Wires & Aluminum sheets | 0.06 kg                    |
| <b>Total weight</b>     | <b>0.24 kg &lt; 0.8 kg</b> |

## CONCLUSION

Initially the project started by determining realistic specifications and requirements demanded by the stakeholders. After the circuit of the power system was implemented, it was tested to verify the specifications. To finalize the project, the CubeSat power system was integrated with the structure and communication subsystems.