

# Fresh V60 Coffee Vending Machine



Talal Al-Turif (Chemical Engineering) - Nasser Al-Saegh (Control & Instrumentation Engineering) - Basil Al-Anazi (Control & Instrumentation Engineering)

Coach: Dr. Umer Zahid

## Introduction/Background

**Problem Statement:** A V60 coffee machine is proposed to ensure consistent taste and quality of the coffee.

## Constraints

**Size:** The machine should fit in various spaces.

**Preparation time:** The machine should produce V60 coffee quickly.

**Ease of use:** The machine should be easy to use.

## Target Specifications

(Compared to conventional machine):

<b>4 Steps Less</b>	<b>15 Seconds Less</b>	<b>10% Less</b>	<b>50% Less</b>	<b>2 Minutes Less</b>

## Conclusion:

The successful development of the V60 coffee machine required a combination of proficiency in design and engineering.

## Conceptualizations

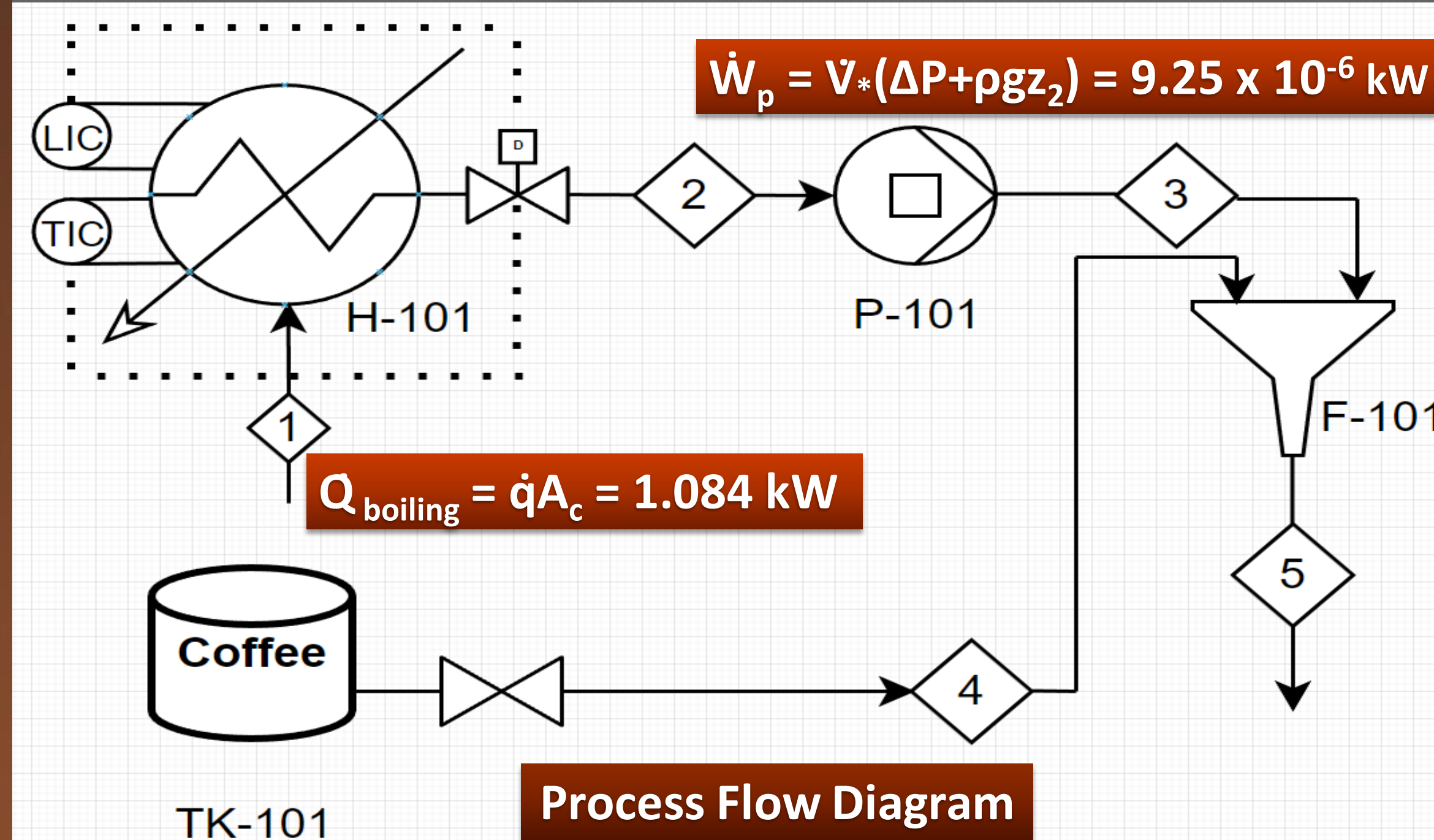

## Testing/Validation

**Steps to order V60 coffee (4 steps less):** Ordering via machine only involves selecting the coffee type and strength.

**Time to order V60 coffee (15 seconds less):** The machine is programmed to remember customer specifications, making the ordering process faster.

**Size of machine (10% less):** Our machine is 45W\*40L\*60H (cm) in dimensions which is over 10% less than Nescafe Coffee Vending Machine whose dimensions are 45W\*45L\*65H (cm).

**Maintenance duration (50% less):** The V60 machine is less likely to malfunction since it is designed to prepare only one type of coffee.

**Time to prepare V60 coffee (2 minutes less):** Experimental results indicate that our machine prepared V60 coffee in two minutes.

## Prototype 3D Design

